

[www.blackanddecker.co.uk](http://www.blackanddecker.co.uk)

ORB48

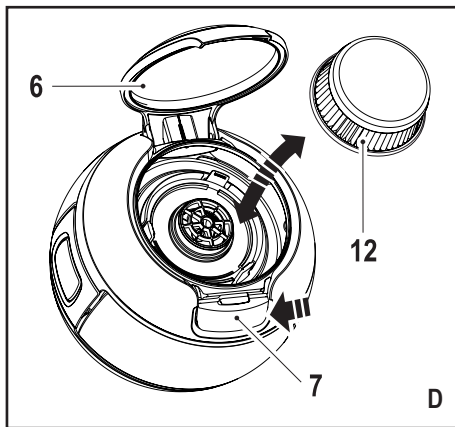

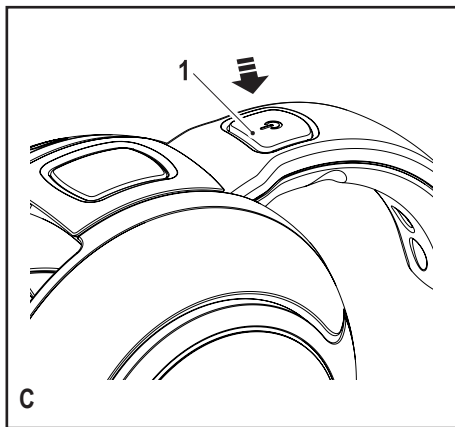
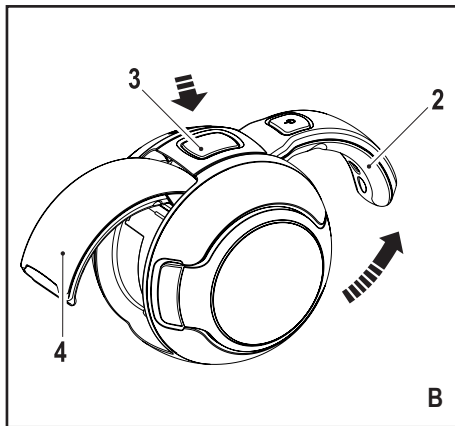
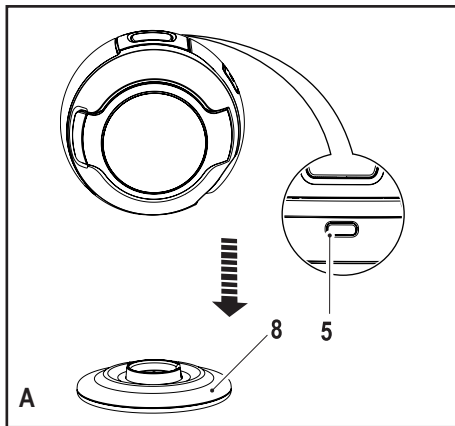
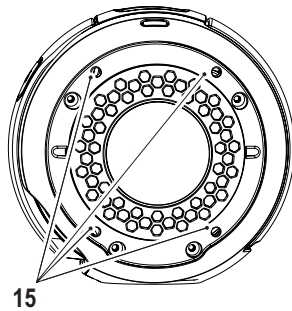
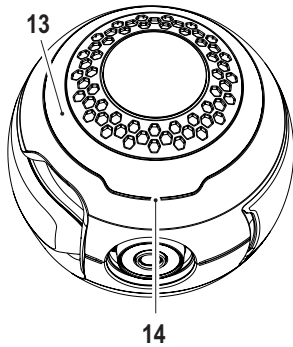

E

## Intended use

Your BLACK+DECKER™ orb-it™ handheld vacuum cleaner has been designed for light dry vacuum cleaning purposes. This appliance is intended for household use only.

## Safety instructions



**Warning! Read all safety warnings and all instructions.** Failure to follow the warnings and instructions listed below may result in electric shock, fire and/or serious injury.



**Warning!** When using battery-powered appliances, basic safety precautions, including the following, should always be followed to reduce the risk of fire, leaking batteries, personal injury and material damage.

- ◆ Read all of this manual carefully before using the appliance.
- ◆ The intended use is described in this manual. The use of any accessory or attachment or the performance of any operation with this appliance other than those recommended in this instruction manual may present a risk of personal injury.
- ◆ Retain this manual for future reference.

## Using your appliance

- ◆ Do not use the appliance to pick up liquids.
- ◆ Do not use the appliance to pick up any materials that could catch fire.

- ◆ Do not use the appliance near water.
- ◆ Do not immerse the appliance in water.
- ◆ Never pull the charger lead to disconnect the charger from the socket. Keep the charger lead away from heat, oil and sharp edges.
- ◆ This appliance is not intended for use by young or infirm persons without supervision. Children must be supervised to ensure they do not play with the appliance.

## After use

- ◆ Unplug the charger before cleaning the charger or charging base.
- ◆ When not in use, the appliance should be stored in a dry place.
- ◆ Children should not have access to stored appliances.

## Inspection and repairs

- ◆ Before use, check the appliance for damaged or defective parts. Check for breakage of parts, damage to switches and any other conditions that may affect its operation.
- ◆ Do not use the appliance if any part is damaged or defective.
- ◆ Have any damaged or defective parts repaired or replaced by an authorized repair agent.
- ◆ Regularly check the charger lead for damage. Replace the charger if the lead is damaged or defective.
- ◆ Never attempt to remove or replace any parts other than those specified in this manual.

## Additional safety instructions - batteries and chargers

### Batteries

- ◆ Never attempt to open for any reason.
- ◆ Do not expose the battery to water.
- ◆ Do not expose the battery to heat.
- ◆ Do not store in locations where the temperature may exceed 40°C.
- ◆ Charge only at ambient temperatures between 10°C and 40°C.
- ◆ Charge only using the charger provided with the appliance/tool. Using the wrong charger could result in an electric shock or overheating of the battery.
- ◆ When disposing of batteries, follow the instructions given in the section "Protecting the environment".
- ◆ Do not damage/deform the battery pack either by puncture or impact, as this may create a risk of injury and fire.
- ◆ Do not charge damaged batteries.
- ◆ Under extreme conditions, battery leakage may occur. When you notice liquid on the batteries carefully wipe the liquid off using a cloth. Avoid skin contact.
- ◆ In case of skin or eye contact, follow the instructions below.

**Warning!** The battery fluid may cause personal injury or damage to property. In case of skin contact, immediately rinse with water. If redness, pain or irritation occurs seek medical attention. In case of eye contact, rinse immediately with clean water and seek medical attention.

### Chargers

Your charger has been designed for a specific voltage. Always check that the mains voltage corresponds to the voltage on the rating plate.

**Warning!** Never attempt to replace the charger unit with a regular mains plug.

- ◆ Use your Black & Decker charger only to charge the battery in the appliance/tool with which it was supplied. Other batteries could burst, causing personal injury and damage.
- ◆ Never attempt to charge non-rechargeable batteries.
- ◆ If the supply cord is damaged, it must be replaced by the manufacturer or an authorised Black & Decker Service Centre in order to avoid a hazard.
- ◆ Do not expose the charger to water.
- ◆ Do not open the charger.
- ◆ Do not probe the charger.
- ◆ The appliance/tool/battery must be placed in a well ventilated area when charging.

### Safety of others

- ◆ This appliance is not intended for use by persons (including children) with reduced physical, sensory or mental capabilities, or lack of experience and knowledge, unless they have been given supervision or instruction concerning the use of the appliance by a person responsible for their safety.
- ◆ Children should be supervised to ensure that they do not play with the appliance.

## Residual risks.

Additional residual risks may arise when using the tool which may not be included in the enclosed safety warnings. These risks can arise from misuse, prolonged use etc.

Even with the application of the relevant safety regulations and the implementation of safety devices, certain residual risks can not be avoided. These include:

- ◆ Injuries caused by touching any rotating/moving parts.
- ◆ Injuries caused when changing any parts, blades or accessories.
- ◆ Injuries caused by prolonged use of a tool. When using any tool for prolonged periods ensure you take regular breaks.
- ◆ Impairment of hearing.
- ◆ Health hazards caused by breathing dust developed when using your tool (example:- working with wood, especially oak, beech and MDF.)

## Electrical safety

Your charger has been designed for a specific voltage. Always check that the mains voltage corresponds to the voltage on the rating plate. Never attempt to replace the charger unit with a regular mains plug.

## Symbols on the charger

**Warning!** Read all of this manual carefully before using the appliance.



This charger is double insulated; therefore no earth wire is required. Always check that the power supply corresponds to the voltage on the rating plate.



Short circuit proof safety isolating transformer. The mains supply is electrically separated from the transformer output.



The charger automatically shuts off if the ambient temperature becomes too high. As a consequence the charger will be inoperable. The charging base must be disconnected from the mains supply and taken to an authorised service centre for repair.



The charging base is intended for indoor use only.

## Features

This tool includes some or all of the following features.

1. On/Off button
2. Handle
3. Handle reset button
4. Nozzle
5. Charging indicator
6. Dust collector cover
7. Cover release button
8. Charging base

## Use

- ◆ Before first use, the battery must be charged for at least 24 hours.
- ◆ Place the appliance on the charging base whenever it is not in use.

## Charging the battery (Fig. A)

- ◆ Place the appliance on the charging base (8)
- ◆ Plug in the charger. Switch on at the mains. The charging indicator (5) will be lit.
- ◆ Leave the appliance to charge for at least 16 hours.

While charging, the charger may become warm. This is normal and does not indicate a problem. The appliance can be left connected to the charger indefinitely. The charging indicator (5) will be lit as long as the appliance is connected to the plugged-in charger.

**Warning!** Do not charge the battery at ambient temperatures below 10 °C or above 40 °C.

## To open the appliance (fig. B)

- ◆ Lift the handle (2) until it clicks into place. The nozzle (4) will automatically lift at the same time.

## To close the appliance (Reset the handle and nozzle) (fig. B)

- ◆ Press the handle release button (3). The nozzle (4) and the handle (2) will fall together.

## Switching on and off (fig. C)

- ◆ To switch the appliance on, press and hold the power button (1).
- ◆ To switch the appliance off, release the power button (1).

**Note:** The handle must be in the open position or the appliance will not turn on.

## Optimising the suction force

In order to keep the suction force optimised, the filters must be cleared regularly during use.

## Emptying the appliance (fig. D)

- ◆ Hold the appliance so that the dust collector cover (6) is facing upwards.
- ◆ Press the cover release button (7) the dust collector cover (6) will open.
- ◆ While holding the appliance over a bin or sink, lift out the filter (12) and empty the contents of the appliance.
- ◆ Replace the filter.
- ◆ Close the dust collector cover (6).

**Note:** The filters are re-usable and should be cleaned regularly.

**Warning!** Never use the appliance without the filters. Optimum dust collection will only be achieved with clean filters.

## Maintenance and cleaning

Your Black & Decker cordless appliance has been designed to operate over a long period of time with a minimum of maintenance. Continuous satisfactory operation depends upon proper appliance care and regular cleaning.

**Warning!** Before performing any maintenance on cordless appliances:

- ◆ Switch off and unplug the appliance.
- ◆ Or switch off and remove the battery from the appliance if the appliance has a separate battery pack.
- ◆ Or run the battery down completely if it is integral and then switch off.
- ◆ Unplug the charger before cleaning it. Your charger does not require any maintenance apart from regular cleaning.

## Cleaning the appliance

- ◆ Regularly clean the ventilation slots in your appliance using a soft brush or dry cloth.
- ◆ Regularly clean the outside of your appliance using a damp cloth. Do not use any abrasive or solvent-based cleaner.
- ◆ The inside of the dust bowl can be cleaned using a soft brush or dry cloth.

## Cleaning the filters

- ◆ The filters can be cleaned using a soft brush or dry cloth.
- ◆ The filters can be washed in warm soapy water.
- ◆ Make sure that the filters are dry before re-fitting.

## Replacing the filters

The filters should be replaced every 6 to 9 months and whenever worn or damaged.

Replacement filters are available from your Black & Decker dealer: Filter part number VFORB10-XJ

## Protecting the environment



Separate collection. This product must not be disposed of with normal household waste.

Should you find one day that your Black & Decker product needs replacement, or if it is of no further use to you, do not dispose of it with household waste. Make this product available for separate collection.



Separate collection of used products and packaging allows materials to be recycled and used again. Re-use of recycled materials helps prevent environmental pollution and reduces the demand for raw materials.

Local regulations may provide for separate collection of electrical products from the household, at municipal waste sites or by the retailer when you purchase a new product.

Black & Decker provides a facility for the collection and recycling of Black & Decker products once they have reached the end of their working life. To take advantage of this service please return your product to any authorised repair agent who will collect them on our behalf.

You can check the location of your nearest authorised repair agent by contacting your local Black & Decker office at the address indicated in this manual. Alternatively, a list of authorised Black & Decker repair agents and full details of our after-sales service and contacts are available on the Internet at: [www.2helpU.com](http://www.2helpU.com)

### Battery (Fig. E)



If you want to dispose of the product yourself, the battery must be removed as described below and disposed of in accordance with local regulations.

- ◆ Discharge the battery by operating the appliance until the motor stops.
- ◆ Using a screwdriver, carefully remove the decorative facia (13) by inserting it into the recess (14) and lifting.
- ◆ Remove the four screws (15) holding the body of the appliance together.
- ◆ Lift the housing cover away from the assembly.
- ◆ Lift out the battery pack / motor assembly.
- ◆ Detach all lead connections from the battery pack / motor assembly.
- ◆ Remove battery pack / motor assembly.
- ◆ Place the battery pack in a suitable package to ensure that the terminals can not be short-circuited.
- ◆ Take the battery to your service agent or to a local recycling station.

Once removed, the battery can not be refitted.

### Technical data

		ORB48 (H1)
Voltage	$V_{dc}$	4.8
Battery	Type	NiMH
Weight	kg	0.75
Charger		BA090020D VA090020D
Input voltage	$V_{ac}$	230
Output voltage	$V_{ac}$	9
Current	mA	200
Approximate charge time	h	16
Weight	kg	0.22

## Guarantee

Black & Decker is confident of the quality of its products and offers an outstanding guarantee. This guarantee statement is in addition to and in no way prejudices your statutory rights. The guarantee is valid within the territories of the Member States of the European Union and the European Free Trade Area.

If a Black & Decker product becomes defective due to faulty materials, workmanship or lack of conformity, within 24 months from the date of purchase, Black & Decker guarantees to replace defective parts, repair products subjected to fair wear and tear or replace such products to ensure minimum inconvenience to the customer unless:

- ◆ The product has been used for trade, professional or hire purposes;
- ◆ The product has been subjected to misuse or neglect;
- ◆ The product has sustained damage through foreign objects, substances or accidents;
- ◆ Repairs have been attempted by persons other than authorised repair agents or Black & Decker service staff.

To claim on the guarantee, you will need to submit proof of purchase to the seller or an authorised repair agent. You can check the location of your nearest authorised repair agent by contacting your local Black & Decker office at the address indicated in this manual. Alternatively, a list of authorised Black & Decker repair agents and full details of our after-sales service and contacts are available on the Internet at: [www.2helpU.com](http://www.2helpU.com)

Please visit our website [www.blackanddecker.co.uk](http://www.blackanddecker.co.uk) to register your new Black & Decker product and to be kept up to date on new products and special offers. Further information on the Black & Decker brand and our range of products is available at [www.blackanddecker.co.uk](http://www.blackanddecker.co.uk)



**Australia**

Black & Decker (Australia) Pty. Ltd.  
20 Fletcher Road, Mooroolbark,  
Victoria, 3138

Tel. 03-8720 5100  
Fax 03-9727 5940

**New Zealand**

Black & Decker  
5 Te Apunga Place  
Mt Wellington  
Auckland 1060

Tel. +64 9 259 1133  
Fax +64 9 259 1122

**United Kingdom**

Black & Decker  
210 Bath Road  
Slough, Berkshire SL1 3YD  
[www.blackanddecker.co.uk](http://www.blackanddecker.co.uk)  
[emeaservice@sbdinc.com](mailto:emeaservice@sbdinc.com)

Tel. 01753 511234  
Fax 01753 512365