

BLACK+
DECKER

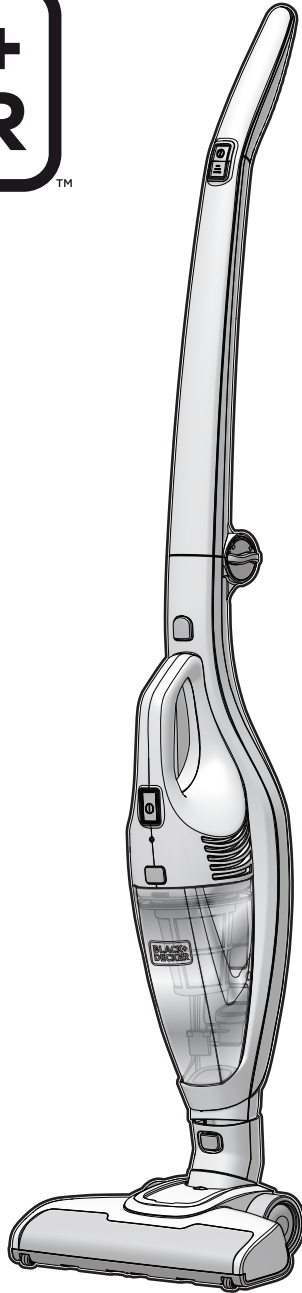

www.blackanddecker.com.au
www.blackanddecker.co.nz

SVB520JW
SVB620JW

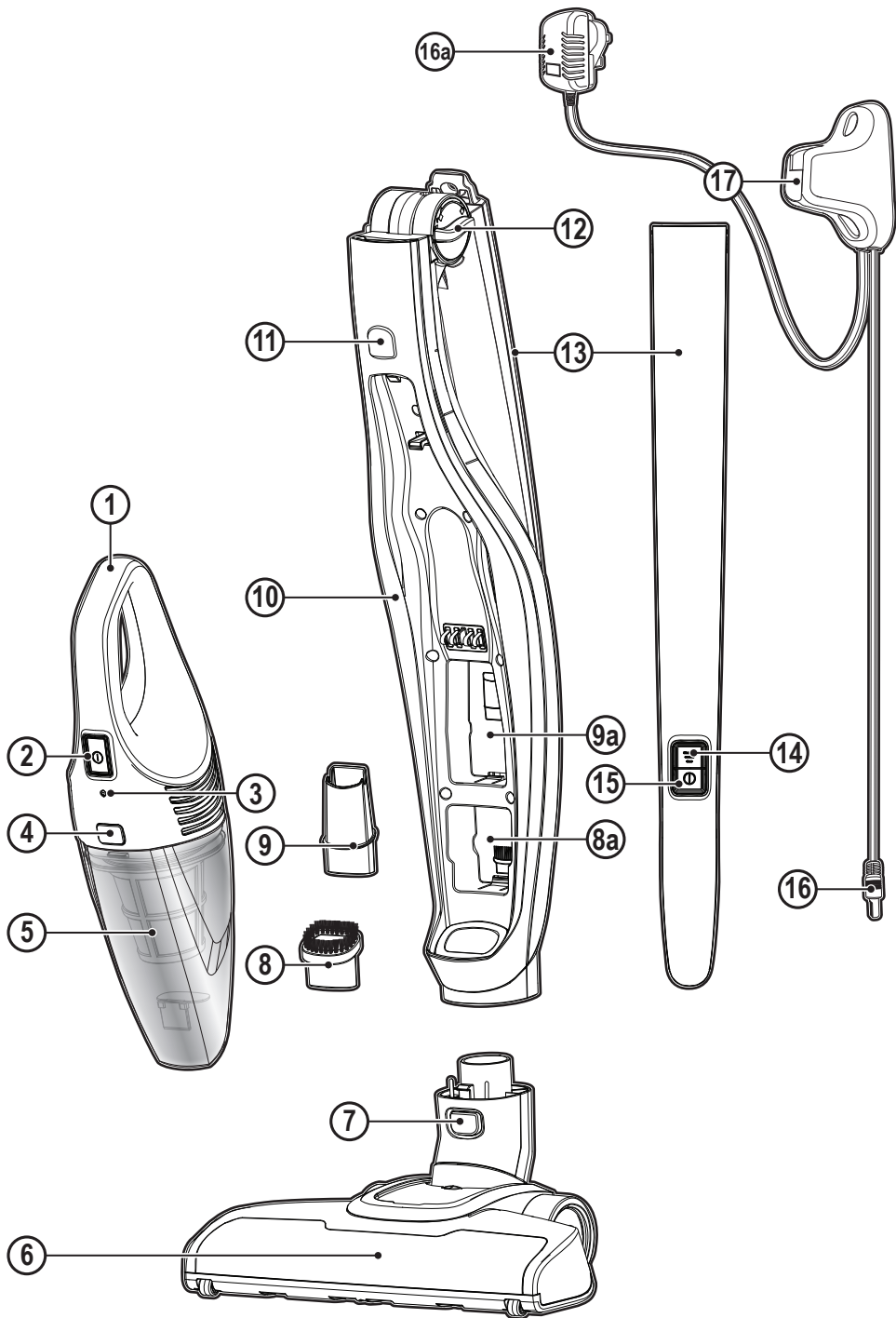

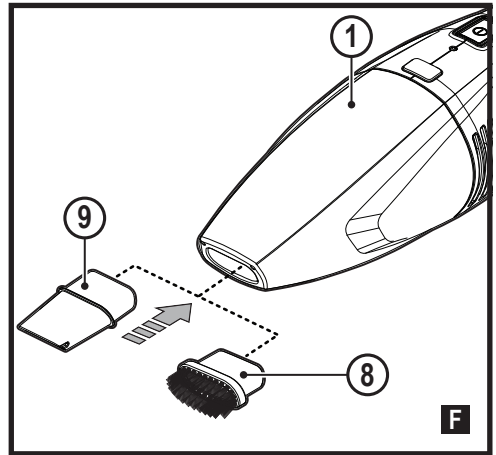
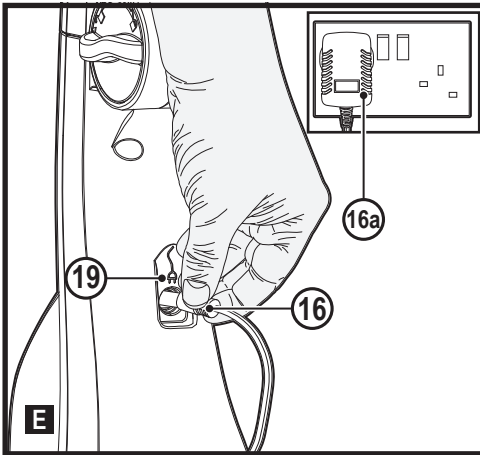
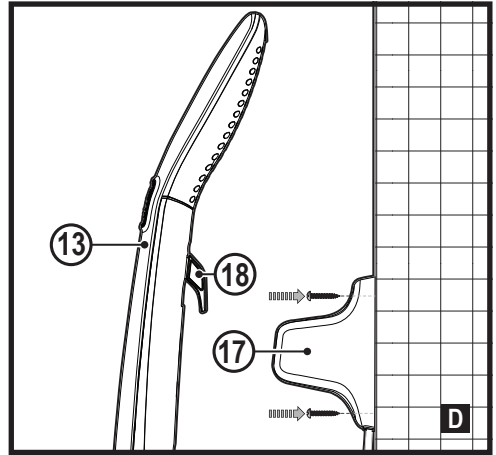
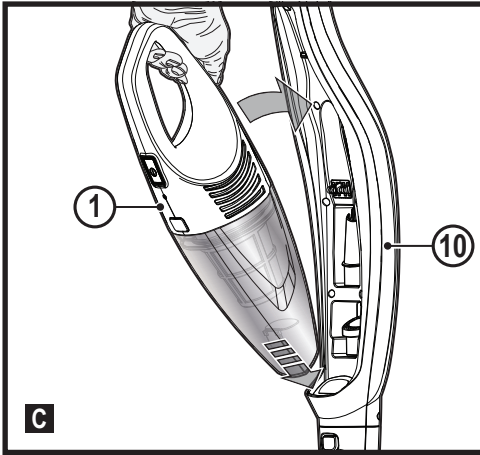
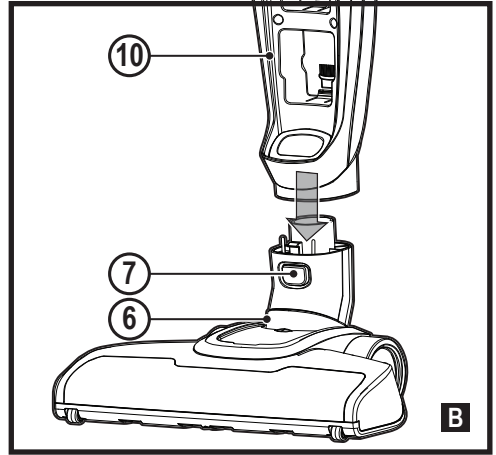
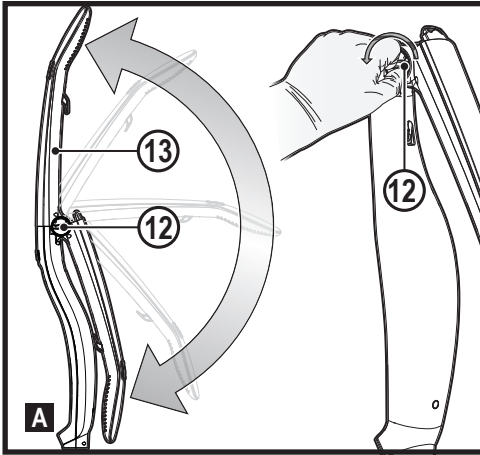

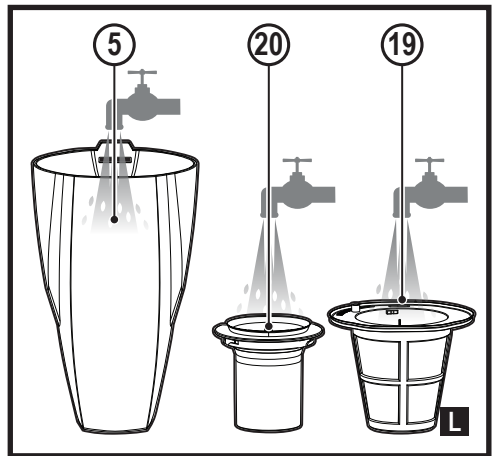
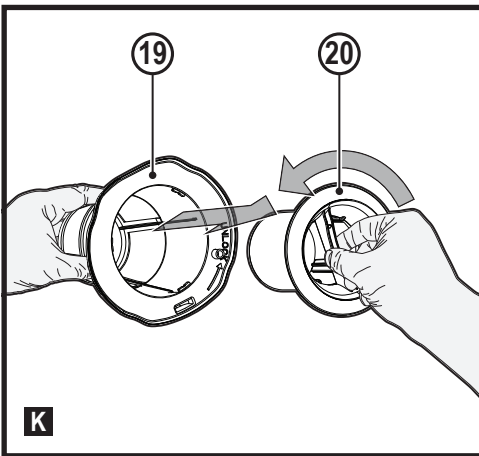
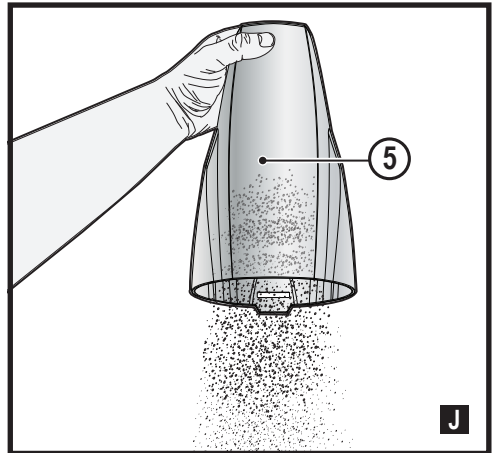
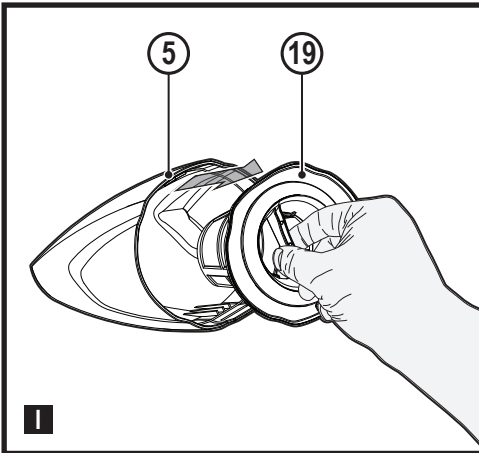
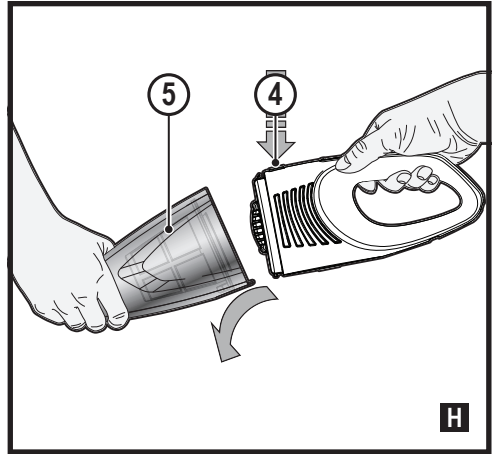
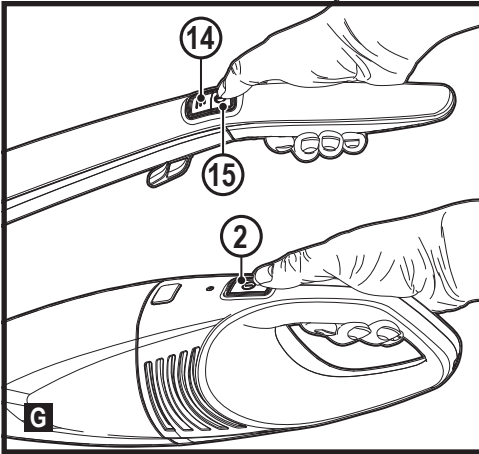

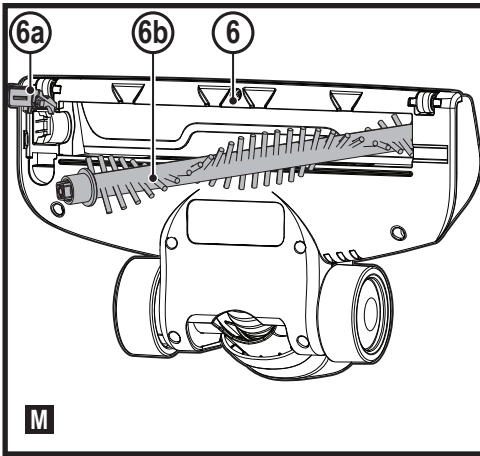

- ◆ This appliance contains batteries that are only replaceable by skilled persons.

Using your appliance

- ◆ Do not use the appliance to pick up liquids or any materials that could catch fire.
- ◆ Do not use the appliance near water.
- ◆ Do not immerse the appliance in water.
- ◆ Never pull the charger lead to disconnect the charger from the socket. Keep the charger lead away from heat, oil and sharp edges.
- ◆ This appliance can be used by children aged from 8 years and above and persons with reduced physical, sensory or mental capabilities or lack of experience and knowledge if they have been given supervision or instruction concerning use of the appliance in a safe way and understand the hazards involved. Children shall not play with the appliance. Cleaning and user maintenance shall not be made by children without supervision.

Intended use

Your BLACK+DECKER SVB520JW and SVB620JW 3 in 1 cordless vacuum cleaners have been designed for vacuum cleaning purposes. These appliances are intended for household use only.



Read all of this manual carefully before operating the appliance.

Safety instructions



Warning! Read all safety warnings and all instructions.

Failure to follow the warnings and instructions listed below may result in electric shock, fire and/or serious injury.

- ◆ The intended use is described in this manual. The use of any accessory or attachment or the performance of any operation with this appliance other than those recommended in this instruction manual may present a risk of personal injury.
- ◆ Retain this manual for future reference.

Inspection and repairs

Before use, check the appliance for damaged or defective parts. Check for breakage of parts, damage to switches and any other conditions that may affect its operation. Do not use the appliance if any part is damaged or defective.

- ◆ Have any damaged or defective parts repaired or replaced by an authorized repair agent.

- ◆ Regularly check the charger lead for damage. Replace the charger if the lead is damaged or defective.
- ◆ Never attempt to remove or replace any parts other than those specified in this manual.

Additional safety instructions

After use

- ◆ Unplug the charger before cleaning the charger or charging base.
- ◆ When not in use, the appliance should be stored in a dry place.
- ◆ Children should not have access to stored appliances.

Residual risks

Additional residual risks may arise when using the tool which may not be included in the enclosed safety warnings. These risks can arise from misuse, prolonged use etc. Even with the application of the relevant safety regulations and the implementation of safety devices, certain residual risks can not be avoided. These include:

- ◆ Injuries caused by touching any rotating/moving parts.
- ◆ Injuries caused when changing any parts, blades or accessories.
- ◆ Injuries caused by prolonged use of a tool. When using any tool for prolonged periods ensure you take regular breaks.
- ◆ Impairment of hearing.
- ◆ Health hazards caused by breathing dust developed when using your tool (example:- working with wood, especially oak, beech and MDF.)

Chargers

Your charger has been designed for a specific voltage. Always check that the mains voltage corresponds to the voltage on the rating plate.

Warning! Never attempt to replace the charger unit with a regular mains plug.

- ◆ Use your BLACK+DECKER charger only to charge the battery in the appliance with which it was supplied. Other batteries could burst, causing personal injury and damage.
- ◆ Never attempt to charge non-rechargeable batteries.
- ◆ If the supply cord is damaged, it must be replaced by the manufacturer or an authorised BLACK+DECKER Service Centre in order to avoid a hazard.
- ◆ Do not expose the charger to water.
- ◆ Do not open the charger.
- ◆ Do not probe the charger.
- ◆ The appliance/battery must be placed in a well ventilated area when charging.

Electrical safety

Symbols on the charger



Read all of this manual carefully before using the appliance.



This tool is double insulated; therefore no earth wire is required. Always check that the power supply corresponds to the voltage on the rating plate.



The charging base is intended for indoor use only.

Labels on appliance

The following symbols appear on this appliance along with the date code



Read all of this manual carefully before using the appliance



SVB520JW use charger JOD-S-220050AU,
BLJ15L220050P-S



SVB620JW use charger JOD-S-270050AU,
BLJ15L270050P-S

Features

This tool includes some or all of the following features.

1. Hand vac
2. On/Off power switch
3. State of charge/discharge indicator
4. Dust bowl release button
5. Dust bowl
6. Floor head
7. Floor head release button
8. Brush tool
- 8a. Brush tool storage recess
9. Crevice tool
- 9a. Crevice tool storage recess
10. Main body
11. Hand vac release button
12. Handle lock
13. Handle
14. Speed selection switch
15. Stick vac On/Off button
16. Charger
- 16a. Charger plug
17. Wall mount

Assembly (Fig. A, B, C)

- ◆ Raise the handle (13) to its operating position until it locks into place. To lower the handle, twist the handle lock (12) to the unlock position as shown in figure A.
- ◆ Align the bottom of the stick vac body (10) with the floor head (6) as shown in figure B.
- ◆ Push the bottom of the stick vac body (10) onto the floor head (6) so it locks into position as shown in figure B.
- ◆ To release the floor head from the stick vac body, press the floorhead release button (7).
- ◆ Insert the hand vac (1) into the stick vac body (10) as shown in figure C, ensuring it clicks firmly into place.
- ◆ To release the hand vac from the stick vac body, press the hand vac release button (11).

Charging the battery (Fig. D, E)

From new, the rechargeable cells of the product need a minimum charge time of 4 hours to ensure full power.

- ◆ Secure the wall mount (17) to a suitable surface near a power outlet, as shown in figure D.
- ◆ The stick vac can be hung from the wall mount via the hook (18) on the back of the handle while charging or being stored.

- ◆ Plug the jack plug of the charger (16) into the charging port (19) located on the stick vac body, as shown in figure E.
- ◆ Plug the charger plug into the power source and switch on, as shown in figure E.
- ◆ The LED (3) flashes red during normal charge and turns green for 60 seconds once charged.
- ◆ Fast RED blink indicates a bad battery pack. Please contact your BLACK+DECKER dealer.

Discharge

- ◆ The LED (3) is green when discharging.
- ◆ The LED flashes green when low battery.
- ◆ The LED flashes RED for 10 seconds once fully discharged.
- ◆ The LED flashes RED when the rotary brush is jammed or entangled. Please refer to section 'Removing and cleaning the rotary brushes'.
- ◆ Once the unit is fully discharged, the LED (3) will flash RED for 10 seconds every time the handvac or stick vac ON/OFF switch is pressed and the unit will not turn on. A charge cycle is required before the unit will turn on.

Hand vac accessories (Fig. F)

Your hand vac may be supplied with some of the following accessories.

- ◆ The brush tool (8) is designed for more effective cleaning of upholstered furniture and fabric.
- ◆ The crevice tool (9) allows for vacuuming in narrow and hard to-reach places.

Fitting accessories

- ◆ Insert the appropriate accessory into the front of the hand vac (1) as show in figure F.
- ◆ Make sure the accessory is fully pushed in.

Note: When not in use the accessories can be stored in the storage recesses (8a) and (9a).

Switching ON and OFF

Hand vac mode

- ◆ To switch ON, press the On/Off power switch (2).
- ◆ To switch OFF, press the On/Off power switch (2).

Stick vac mode

- ◆ To switch On, press the stick vac On/Off button (15).
- ◆ For decreased performance press the speed selection switch (14).
- ◆ To switch OFF, press the stick vac On/Off button (15).

Note: Return the product to the charger immediately after use so that it will be ready and fully charged for the next use. Ensure that the product is fully engaged with the charger plug. The unit must be placed on charge for it to run once it is fully discharged.

Emptying and cleaning (Fig. H, I, J, K, L)

- ◆ Press the dust bowl release button (4) and pull the dust bowl (5) straight off as shown in figure H.
- ◆ While holding the dust bowl over an appropriate waste receptacle, pull out the filter assembly (19) as shown in figure I.
- ◆ Empty the dust bowl (5) into an appropriate waste receptacle as shown in figure J
- ◆ Rotate filter (20) counterclockwise to unlock and remove it from the pre filter assembly (19). Gently remove any debris.
- ◆ Rinse out the dust-bowl with warm soapy water as shown in figure L.
- ◆ Wash the filters with warm soapy water as shown in figure L.
- ◆ Make sure the filters are dry before reassembling.
- ◆ Refit the filters into the dust bowl and ensure that they are correctly seated.
- ◆ replace the dust bowl onto the hand vac making sure the release latch (4) clicks into place.

Warning! Never use the appliance without the filters. Optimum dust collection will only be achieved with a clean filter.

Removing and cleaning the rotary brushes (Fig. M)

Warning! To reduce the risk of injury from moving parts, disconnect the floor head from the stick vac before cleaning or servicing.

- ◆ To remove the rotary brush (6b), lift the plastic tab (6a) located on the floor head (6).
- ◆ Lift the rotary brush (6b) out of the floor head. Clear the brushes of any hair or other debris that may have accumulated.
- ◆ Replace rotary brush, and secure plastic tab before using vacuum.

Safe storage

The unit can be safely stored, when not in use, either by utilising the wall mount (17) or releasing the handle lock (12) and lowering the handle (13) to allow for storage in confined areas.

Maintenance

Your BLACK+DECKER cordless appliance has been designed to operate over a long period of time with a minimum of maintenance. Continuous satisfactory operation depends upon proper tool care and regular cleaning.

Warning! Before performing any maintenance on cordless appliances:

- ◆ Run the battery down completely if it is integral and then switch off.
- ◆ Unplug the charger before cleaning it. Your charger does not require any maintenance apart from regular cleaning.

- ◆ Regularly clean the ventilation slots in your appliance/charger using a soft brush or dry cloth.
- ◆ Regularly clean the motor housing using a damp cloth. Do not use any abrasive or solvent-based cleaner.

Replacing the filters

The filters should be replaced every 6 to 9 months and whenever worn or damaged. Replacement filters are available from your BLACK+DECKER dealer.

- ◆ Remove the old filters as described above.
- ◆ Fit the new filters as described above.

Protecting the environment



Separate collection. Products and batteries marked with this symbol must not be disposed of with normal household waste.

Products and batteries contain materials that can be recovered or recycled reducing the demand for raw materials. Please recycle electrical products and batteries according to local provisions. Further information is available at www.2helpU.com

Technical Data

	SVB520JW	SVB620JW
Voltage	18V	21.6V
Watt Hours	36Wh	43.2Wh
Weight with accessories	2.34Kg	2.39Kg

Australia & New Zealand

Stanley Black & Decker

www.blackanddecker.com.au

www.blackanddecker.co.nz

Tel. 1800 338 002 (Aust) or Tel. 0800 339 258 (NZ)