

# STANLEY

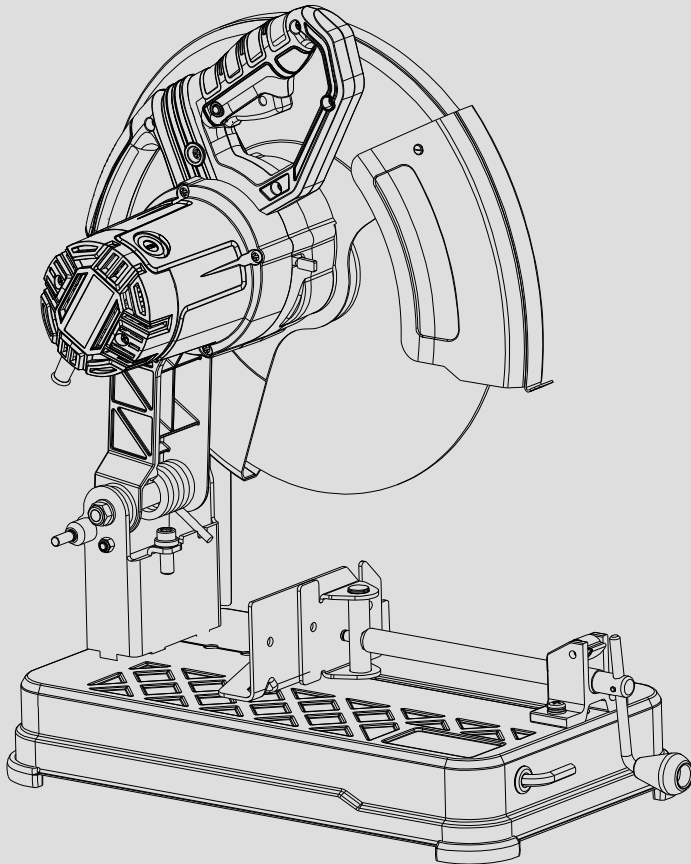

**STSC2135**

English

Page 3

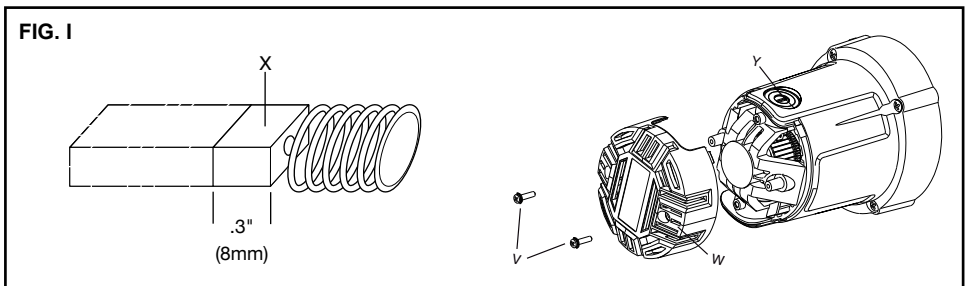
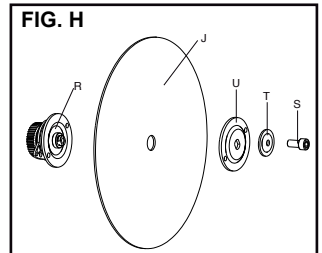
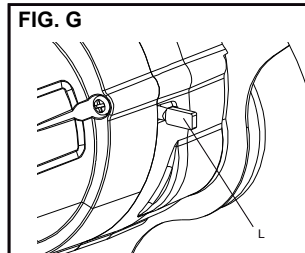
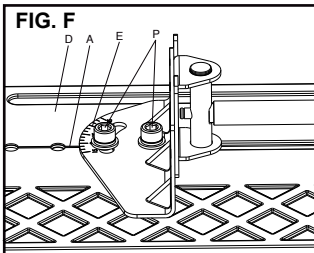
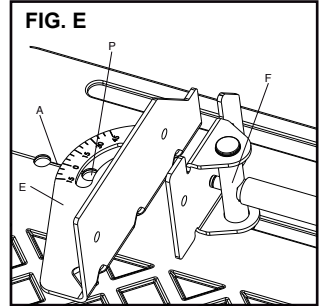
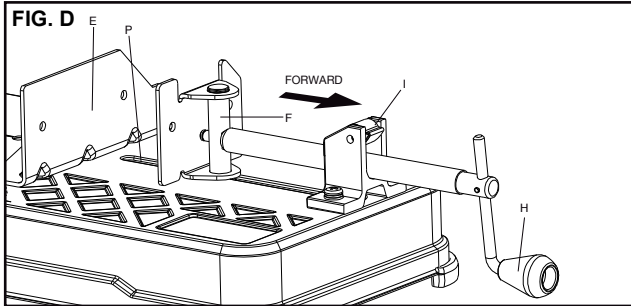
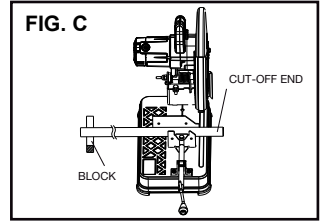
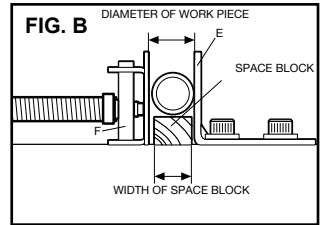
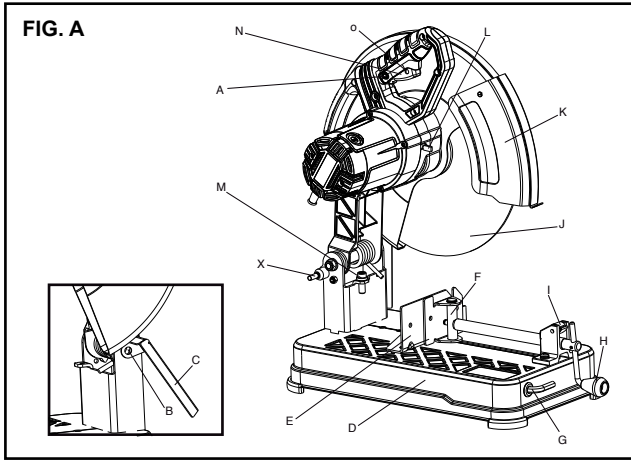

## Intended use

Your STANLEY Chop Saw has been designed for the cutting of variously shaped steel materials.

## General safety rules

**Warning!** Read all instructions. Failure to follow all instructions listed below may result in electric shock, fire and/or serious injury. The term "power tool" in all of the warnings listed below refers to your mains operated (corded) power tool or battery operated (cordless) power tool. **SAVE THESE INSTRUCTIONS.**

## Safety instructions

### General power tool safety warnings

#### 1. Work area safety

- a. **Keep work area clean and well lit.** Cluttered and dark areas invite accidents.
- b. **Do not operate power tools in explosive atmospheres, such as in the presence of flammable liquids, gases or dust.** Power tools create sparks which may ignite the dust or fumes.
- c. **Keep children and bystanders away while operating a power tool.** Distractions can cause you to lose control.

#### 2. Electrical safety

- a. **Power tool plugs must match the outlet. Never modify the plug in any way. Do not use any adapter plugs with earthed (grounded) power tools.** Unmodified plugs and matching outlets will reduce risk of electric shock.
- b. **Avoid body contact with earthed or grounded surfaces such as pipes, radiators, ranges and refrigerators.** There is an increased risk of electric shock if your body is earthed or grounded.
- c. **Do not expose power tools to rain or wet conditions.** Water entering a power tool will increase the risk of electric shock.
- d. **Do not abuse the cord. Never use the cord for carrying, pulling or unplugging the power tool. Keep cord away from heat, oil, sharp edges or moving parts.** Damaged or entangled cords increase the risk of electric shock.
- e. **When operating a power tool outdoors, use an extension cord suitable for outdoor use.** Use of a cord suitable for outdoor use reduces the risk of electric shock.
- f. **If operating a power tool in a damp location is unavoidable, use a residual current device (RCD) protected supply.** Use of an RCD reduces the risk of electric shock.

**Note:** The term "Residual Current Device (RCD)" can be replaced by "Ground Fault Circuit Interrupter (GFCI)" or by "Earth Leakage Circuit Breaker (ELCB)".

#### 3. Personal safety

- a. **Stay alert, watch what you are doing and use common sense when operating a power tool. Do not use a power tool while you are tired or under the influence of drugs, alcohol or medication.** A moment of inattention while operating power tools may result in serious personal injury.
- b. **Use safety equipment. Always wear eye protection.** Safety equipment such as dust mask, non-skid safety shoes, hard hat, or hearing protection used for appropriate conditions will reduce personal injuries.
- c. **Avoid accidental starting. Ensure the switch is in the off position before plugging in.** Carrying power tools with your finger on the switch or plugging in power tools that have the switch on invites accidents.
- d. **Remove any adjusting key or wrench before turning the power tool on.** A wrench or a key left attached to a rotating part of the power tool may result in personal injury.
- e. **Do not overreach. Keep proper footing and balance at all times.** This enables better control of the power tool in unexpected situations.
- f. **Dress properly. Do not wear loose clothing or jewellery. Keep your hair, clothing and gloves away from moving parts.** Loose clothes, jewellery or long hair can be caught in moving parts.
- g. **If devices are provided for the connection of dust extraction and collection facilities, ensure these are connected and properly used.** Use of these devices can reduce dust related hazards.

#### 4. Power tool use and care

- a. **Do not force the power tool. Use the correct power tool for your application.** The correct power tool will do the job better and safer at the rate for which it was designed.
- b. **Do not use the power tool if the switch does not turn it on and off.** Any power tool that cannot be controlled with the switch is dangerous and must be repaired.
- c. **Disconnect the plug from the power source and/or the battery pack from the power tool before making any adjustments, changing accessories, or storing power tools.** Such preventive safety measures reduce the risk of starting the power tool accidentally.

- d. **Store idle power tools out of the reach of children and do not allow persons unfamiliar with the power tool or these instructions to operate the power tool.** Power tools are dangerous in the hands of untrained users.
  - e. **Maintain power tools. Check for misalignment or binding of moving parts, breakage of parts and any other condition that may affect the power tools operation. If damaged, have the power tool repaired before use.** Many accidents are caused by poorly maintained power tools.
  - f. **Use the power tool, accessories and tool bits etc., in accordance with these instructions, taking into account the working conditions and the work to be performed.** Use of the power tool for operations different from those intended could result in a hazardous situation.
5. **Service**
- a. **Have your power tool serviced by a qualified repair person using only identical replacement parts.** This will ensure that the safety of the power tool is maintained.

### Additional safety instruction for chopsaws

- **Always wear proper eye and respiratory protection.**
- **Before using, inspect the cutting wheel for cracks or flaws. If such a crack or flaw is evident, discard the wheel. The wheel should also be inspected whenever you think the tool may have been dropped.** Flaws may cause wheel breakage.
- **When starting the tool with a new or replacement wheel or if you are unsure of the condition of the wheel, hold the tool in a well protected area and let it run for one minute.** If the wheel has an undetected crack or flaw, it should burst in less than one minute. Never start the tool with a person in line with the wheel. This includes the operator.
- **In operation, avoid bouncing the wheel or giving it rough treatment.** If this occurs, stop the tool and inspect the wheel for cracks or flaws.

### During use

- If the saw blade becomes blocked, switch off the tool immediately and disconnect the plug; only then remove the wedged workpiece
- In case of jamming or electrical or mechanical malfunction, immediately switch off the tool and disconnect the plug
- Clean your chop saw periodically following the procedure in this manual.
- Do not remove wheel guards or base.
- **ALWAYS USE THE VISE OR SPECIAL FIXTURE TO CLAMP WORK SECURELY.** Other aids such as spring, bar, or C-clamps may be appropriate for certain sizes and shapes of workpiece. Use care in selecting and placing these clamps and make a dry run before making a cut.
- Use only 14" type 1 wheels rated at 4100 rpm or higher.
- Allow cut off parts to cool before handling.
- Do not attempt to cut wood or plastic with this tool.
- **NEVER CUT MAGNESIUM WITH THIS TOOL.**
- Use chop saw in a well-ventilated area.
- Turn chop saw off before removing any pieces from the base.
- **DO NOT CUT ELECTRICALLY LIVE MATERIAL.**
- **Do not use circular saw blades or any other toothed blades with this tool.** Serious injury may result.
- **DO NOT OPERATE THIS TOOL NEAR FLAMMABLE LIQUIDS, GASES OR DUST.** Sparks or hot chips from cutting or arcing motor brushes may ignite combustible materials.
- Do not use the side of the abrasive wheel as a deburring grinder. This will substantially weaken the wheel creating an unsafe condition. The wheel may come apart.



**Caution: Wear appropriate hearing protection during use.** Under some conditions and duration of use, noise from this product may contribute to hearing loss.



**Caution:** Spark deflector will get hot. Avoid touching or adjusting while hot. Keep cord set and materials away from spark deflector.

- **Avoid prolonged contact with dust from power sanding, sawing, grinding, drilling, and other construction activities. Wear protective clothing and wash exposed areas with soap and water.** Allowing dust to get into your mouth, eyes, or lay on the skin may promote absorption of harmful chemicals.



**Warning:** Always use NIOSH/OSHA approved respiratory protection appropriate for the dust exposure. Direct particles away from face and body. For your convenience and safety, the following warnings are on your Heavy-Duty 14" (355mm) Chop Saw:



**For safe operation read the instruction manual.**

- **Do not use toothed blades.**
- **Use only reinforced wheels rated 4100 rpm or higher.**
- **When servicing use only identical replacement parts.**
- **Always: wear eye protection, use guards, clamp work in vise, use proper respiratory protection.**
- **Do not expose to rain or use in damp locations.**
- **Only use chop saw wheel of a max. Thickness of 2.8mm and a max. Diameter of 355mm.**

### Vibration

The declared vibration emission values stated in the technical data and the declaration of conformity have been measured in accordance with a standard test method provided by EN 61029 and may be used for comparing one tool with another. The declared vibration emission value may also be used in a preliminary assessment of exposure.

**Warning!** The vibration emission value during actual use of the power tool can differ from the declared value depending on the ways in which the tool is used. The vibration level may increase above the level stated.

When assessing vibration exposure to determine safety measures required by 2002/44/EC to protect persons regularly using power tools in employment, an estimation of vibration exposure should consider, the actual conditions of use and the way the tool is used, including taking account of all parts of the operating cycle such as the times when the tool is switched off and when it is running idle in addition to the trigger time.

### 7. Labels on tool

The label on your tool may include the following symbols:

	Read Instructions Manual	Hz .....	Hertz		.....	Class II Construction
	Use Eye Protection	W .....	Watts		.....	Earthing Terminal
	Use Ear Protection	min .....	minutes		.....	Safety Alert Symbol
			.....	.....	.....	Revolutions or Reciprocation per minute
			.....			
V .....	Volts	$n_0$ .....	No-Load Speed			
A .....	Amperes					

### Position of date barcode

The Date Code, which also includes the year of manufacture, is printed into the housing.

Example:

2014 XX JN  
Year of manufacturing

### Electrical safety

**Warning!** If the power cord is damaged, it must be replaced by the manufacturer, authorized Stanley Service Center or an equally qualified person in order to avoid damage or injury. If the power cord is replaced by an equally qualified person, but not authorized by Stanley, the warranty will not be valid.

### Features (fig. 1, 4)

- A. Spark Deflector Screw
- B. Spark Deflector
- C. Base
- D. Fence
- E. Vise
- F. Flat Wrench
- G. Crank
- H. Vise Level
- I. Wheel
- J. Guard
- K. Spindle Lock
- L. Depth Stop Bolt and Jam Nut

- M. Trigger Switch
- N. Padlock Hole
- O. Fence Bolts
- P. Lock Pin

**Power supply**

Be sure your power supply agrees with the nameplate marking. A voltage decrease of more than 10% will cause a loss of power and overheating.

**Cutting capacity**

The wide vise opening and high pivot point provide cutting capacity for many large pieces. Use the cutting capacity chart to determine total maximum size of cuts that can be made with a new wheel.



**Caution: Certain large, circular or irregularly shaped objects may require additional holding means if they cannot be held securely in vise.**



**Caution: do not cut magnesium with this tool.**

**Maximum cutting capacity**

**Note:** Capacity shown on chart assumes no wheel wear and optimum fence position.

Workpiece Shape:				
90° Cutting Angle	A = 4-7/8" (125mm)	A = 4-1/2" (115mm)	4-1/2" x 5-1/8" (115mm x 130mm) 4" x 7-5/8" (102mm x 188mm) 3" x 7-3/8" (76mm x 229mm)	A = 4-1/2" x 5-3/8" (115mm x 137mm)
45° Cutting Angle	A = 4-1/2" (115mm)	A = 3-13/16" (98mm)	4-1/2" x 3-13/16" (115mm x 95mm) 4-1/8" x 3-3/4" (105mm x 95mm)	A = 3-13/16" 3-3/4" (95mm)

**Use**

**Standard equipment**

- 355mm Metal Cutting Abrasive Wheel
- 1 Wheel Wrench
- 1 Instruction manual

**To carry (fig. 1)**

Fold down unit to position where you can carry the saw. Push in lock pin (X) to lock arm down.

**Unlocking (fig. 1)**

To unlock tool and raise head, depress motor arm slightly and pull lock pin (X) out. Motor arm will then pivot upward.

**Spark deflector adjustment (fig. 1)**

To best deflect sparks away from surrounding persons and materials, loosen the screw (A), adjust the spark deflector (B) and then retighten screw. Do not allow cordset to come into contact with deflector or sparks as damage to cordset may occur.

**Depth stop (fig. 1)**

Depth stop is set at the factory for a new 14" wheel to prevent wheel from cutting into the supporting surface. To allow more depth of cut, use the flat wrench provided (F) to loosen the depth stop bolt (L) and raise bolt to desired height and then turn jam nut (L) clockwise until seated firmly on the casting. Securely tighten the depth stop bolt before use.



**Caution:** When changing to a new wheel, readjust depth stop to original position to prevent cutting into supporting surface.

**Trigger switch (fig. 1)**

To start the tool, depress the trigger switch (M). To turn the tool off, release the trigger switch. Keep hands and material from wheel until it has coasted to a stop. To prevent unauthorized use of tool, install a standard padlock (not included) into the padlock hole (N) located in the trigger.

**Material clamping and supporting**

- Angles are best clamped and cut with both legs resting against base.
- A spacer block slightly narrower than the work piece can be used to increase wheel utilization (Fig. 2).
- Long work pieces must be supported by a block so it will be level with top of base (Fig. 3). The cut off end should be free to fall downward to avoid wheel binding.

**Vise operation (fig. 4)**

The vise (E) has a quick-travel feature. To release the vise when it is clamped tightly, turn the crank (G) counterclockwise one or two times to remove clamping pressure. Lift vise lever (H) up. Pull crank assembly out as far as desired. Vise may be pushed forward into work without cranking. Lower vise lever (H) then tighten vise (E) on work by using crank (G).

**Fence operation (fig. 5, 6)**



**Caution: Turn off and unplug the tool before making any adjustments or removing or installing attachments or accessories. Be sure the trigger switch is in the OFF position.** The fence (D) can be adjusted two ways: to change desired cutting angle and to change spacing between the fence and vise.

### To change the desired cutting angle

Use the wrench provided to loosen (do not remove) the two fence bolts (O). Align the desired angle indicator line with the slot line in the base (C). Securely tighten both fence bolts before use. For more accurate square cuts, disconnect the power supply, loosen the two fence bolts, push arm down until wheel extends into base. Place a square against the wheel and adjust fence against the square. Securely tighten both fence bolts before use. When making a miter cut, the vise (E) may not clamp securely, depending on the thickness of the workpiece and the miter angle. Other aids (such as spring, bar or C-clamps) will be necessary to secure the work piece to the fence when making these cuts.

### To change spacing between the fence and vise

Using the wrench provided, loosen and remove the two fence bolts (O). Adjust the fence (D) to desired locations. Insert both fence bolts in provided locations. Securely tighten both fence bolts before use.

### Removal and installation of wheels (fig. 7, 8)



**Caution:** Turn off and unplug the tool before making any adjustments or removing or install attachments or accessories. Be sure the trigger switch is in the OFF position. Do not make any adjustment while the wheel is in motion. Do not make any adjustment while chop saw is plugged into power supply.

1. Push in spindle lock (K) and rotate wheel (I) by hand until wheel lock lever engages slot in inside flange (Q) to lock wheel. Loosen the bolt (R) counterclockwise in the center of the abrasive wheel with the 8mm hex wrench (F). Bolt has right-hand thread.
2. Remove the bolt (S), washer (R), outside flange (T) and old wheel (I).
3. Make sure flange surfaces are clean and flat. Install the new abrasive wheel by reversing the above steps.
4. Do not overtighten bolt.



**Warning:** Check the work surface that the chop saw rests on when replacing with a new abrasive wheel. It is possible that the wheel may contact ANY ITEMS OR STRUCTURE THAT EXTENDS

ABOVE work surface (under the base) when the arm is fully lowered.

### Operation tips for more accurate cuts

- Allow the wheel to do the cutting. Excessive force will cause the wheel to glaze reducing cutting efficiency and/or to deflect causing inaccurate cuts.
- Properly adjust fence angle.
- Make sure material is laying flat across base.
- Properly clamp material to avoid movement and vibration.

### Motor brush inspection and replacement (fig.9)



**Warning:** Turn off and unplug the tool. Be sure the trigger switch is in the OFF position.

Brushes should be regularly inspected for wear. To inspect brushes, unscrew the two end cap screws (V) and remove end cap (W). Remove brush cap (Y). Brushes (X) should slide freely in brush box.

If brushes are worn down to .3" (8mm) as shown in Figure 9 they should be replaced. To reinstall, push new brush back into brushbox. If replacing existing brush, maintain same orientation as when removed. Replace the brush cap (do not overtighten). Replace end cap and two screws. Tighten securely.

### Accessories

The performance of any power tool is dependent upon the accessory used. STANLEY accessories are engineered to high quality standards and are designed to enhance the performance of power tool.



**Note:** Accessory must be rated for use at speed equal to or higher than nameplate RPM of tool with which it is being used.

**Caution:** The use of any other accessory not recommended for use with this tool could be hazardous. Use only high-strength Type 1 organic bonded wheels rated 4100 rpm or higher. Recommended accessories for use with your tool are available at extra cost from your local dealer or authorized service center.

### Maintenance

Your STANLEY power tool has been designed to operate over a long period of time with a minimum of maintenance. Continuous satisfactory operation depends upon proper tool care and regular cleaning. Your tool is not user-serviceable. Take the tool to an authorized STANLEY repair agent. This tool should be serviced at regular intervals or when showing a noticeable change in performance.

### Lubrication

STANLEY power tools are properly lubricated at the factory and are ready for use. Tools should be re-lubricated regularly, depending on usage. This lubrication should only be attempted by trained power tool repair persons, such as those at STANLEY service centers or by other qualified service personnel. Closed-type, grease-sealed ball bearings are used throughout. These bearings have sufficient lubrication packed in them at the factory to last the life of the chop saw.

### Cleaning



**Warning:** unplug the tool before you use a cloth to clean the housing. With the motor running, blow dirt and dust out of all air vents with dry air at least once a week. Wear safety glasses when performing this. Exterior plastic parts may be cleaned with a damp cloth and mild detergent. Although these parts are highly solvent resistant, NEVER use solvents.

Blowing dust and grit out of the main housing by means of an air hose is recommended and may be done as often as dirt is seen collecting in and around the air vents. Always wear proper eye and respiratory protection.

### Tool care

Avoid overloading the machine. Overloading will result in a considerable reduction in speed and efficiency and the unit will become hot. In this event, run the machine at no load for a minute or two until cooled to normal working temperature

by the built in fan. Switching your machine on and off whilst under load will considerably reduce the life of the switch.

### Important

To ensure product SAFETY and RELIABILITY, repairs, maintenance and adjustment (other than those listed in this manual) should be performed by authorized service centers or other qualified organizations, always using identical replacement parts. Unit contains no user serviceable parts inside. Blowing dust and grit out of the main housing by means of an air hose is recommended and may be done as often as dirt is seen collecting in and around the air vents. Always wear proper eye and respiratory protection.

**Note:** Unit may be converted to a 3-wire twist lock cord set at an authorized service center.

### Notes

- STANLEY's policy is one of continuous improvement to our products and, as such, we reserve the right to change product specifications without prior notice.
- Standard equipment and accessories may vary by country.
- Product specifications may differ by country.
- Complete product range may not be available in all countries.
- Contact your local STANLEY dealers for range availability.

## Protecting the environment



Separate collection. This product must not be disposed of with normal household waste.

Should you find one day that your STANLEY product needs replacement, or if it is of no further use to you, do not dispose of it with household waste. Make this product available for separate collection.



Separate collection of used products and packaging allows materials to be recycled and used again.

Re-use of recycled materials helps prevent environmental pollution and reduces the demand for raw materials.

Local regulations may provide for separate collection of electrical products from the household, at municipal waste sites or by the retailer when you purchase a new product. STANLEY provides a facility for the collection and recycling of STANLEY products once they have reached the end of their working life. To take advantage of this service please return your product to any authorised repair agent who will collect them on our behalf.

You can check the location of your nearest authorised repair agent by contacting your local STANLEY office at the address indicated in this manual. Alternatively, a list of authorised STANLEY repair agents and full details of our after-sales service and contacts are available on the Internet at: [www.2helpU.com](http://www.2helpU.com)

## EC declaration of conformity

MACHINERY DIRECTIVE



**STSC2135**

STANLEY declares that these products described under "technical data" are in compliance with: 2006/42/EC, EN 61029-1, EN 61029-2-10

These products also comply with Directive 2004/108/EC (until 19.04.2016), 2014/30/EU (from 20.04.2016) and 2011/65/EU.

For more information, please contact STANLEY at the following address or refer to the back of the manual.

The undersigned is responsible for compilation of the technical file and makes this declaration on behalf of STANLEY.

R.Laverick

Engineering Manager

STANLEY, Europe, Egide Walschaertsstraat14-18,  
2800 Mechelen, Belgium  
01.2015

## Technical data

Specifications		STSC2135
POWER	W	2100
NO-LOAD SPEED	/min	3800
MAX. DIAMETER	mm	355
Weight	kg	15.5

$L_{pA}$  (sound pressure) dB(A) 95,5

$K_{pA}$  (sound pressure uncertainty) dB(A) 3

$L_{WA}$  (sound power) dB(A) 105,5

$K_{WA}$  (sound power uncertainty) dB(A) 3

Vibration emission value  $a_h$

$a_h =$  m/s<sup>2</sup> 4.3

Uncertainty K = m/s<sup>2</sup> 1.5

## **Service Information**

STANLEY offers a full network of company-owned and authorized service locations. All STANLEY Service Centers are staffed with trained personnel to provide customers with efficient and reliable power tool service. For more information about our authorized service centers and if you need technical advice, repair, or genuine factory replacement parts, contact the STANLEY location nearest you.

## **One years full warranty**

If your STANLEY product becomes defective due to faulty materials or workmanship within 12 months from the date of purchase, STANLEY guarantees to replace all defective parts free of charge or – at our discretion – replace the unit free of charge provided that:

- The product has not been misused and has been used in accordance with the instruction manual.
- The product has been subject to fair wear and tear;
- Repairs have not been attempted by unauthorised
  
- Proof of purchase is produced.
- The STANLEY product is returned complete with all original components

If you wish to make a claim, contact your seller or check the location of your nearest authorised STANLEY repair agent in the STANLEY catalogue or contact your local STANLEY office at the address indicated in this manual. A list of authorised STANLEY repair agents and full details of our after sales service is available on the internet at:[www.stanleytools.com](http://www.stanleytools.com)



## Names & Addresses for STANLEY Service Concessionaries - MIDDLE EAST & AFRICA

**ALGERIA:** Sarl Outillage Corporation, 08 Rue Med Boudiaf - Cheraga - Algiers, Algeria. Tel: (213-21) 375130, Fax: (213-21) 369667. **ANGOLA:** Angoferraria, Lda., Rua Robert Shields, No. 61, Luanda, Angola. Tel: 00244-222-395837 / 222-395034, Fax: 00244-222-394790. **AZERBAIJAN:** Royalton Holdings Ltd. 41 Khagani St. Apt. 47 AZ 1001, Baku. Tel: (994-12) 4935544, Fax: (994-12) 5980378. **BAHRAIN:** Kavalani & Sons W.L.L., P.O. Box 71, Sitra, Manama, Tel: (973) 17732888, Fax: (973) 17737379. Alfouz Services Co. W.L.L., P.O. Box 26562, Tubli, Manama. Tel: (973) 17783562, Fax: (973) 17783479. **Egypt:** El Farab S.A.E., 15-Nabil El Wakkad Street, Dokki, Giza, Egypt. Tel: 00202-37603946 / 002-010-2582544, Fax: 00202-33352796. **ETHIOPIA:** Seif Tewfik Sherif, Arada Sub-City, Kebele 01/02, Global Insurance Building, 2nd Floor, Room 43, P.O. Box 2525, Addis Ababa, Ethiopia. Tel: (251-11) 1563968/ 1563969, Fax: (251-11) 1558009. **IRAQ:** Financial Links, Kazzaz Building Ararat Al-Hindia Block No: 629 Street: 31 Building No: 1 Baghdad - Iraq. Tel: 00964 (0)780 195 2223/ 00964 (0)781 3763044. Al Sard Co. for General Trading Ltd. Jbara Bldg. 3Flr, Al Rasheed St. Bagdad. Tel: (964) 18184102. Sakhar Group, Arrasat al-hindya Al Masbah, Baghdad. (964) 7400144446. **JORDAN:** Palestine Bldg. Matl. (Bashiti Hardware), 93 King Abdullah 2nd Street. Opp. ELBA House, P.O. Box 3005, Amman 11953, Tel: (962-6) 5349098, Fax: (962-6) 5330731. **KENYA:** Dextron Tools Ltd., P.O. Box 20121-00200, Shariff House, Kimathi Street, Nairobi. Tel: (254-20) 6905000/ 2358021, Fax: (254-20) 6905111/ 6905112. **KUWAIT:** Al Omar Technical Co., P.O. Box 4062, 13041 Safat, Kuwait. Tel: (965) 24848595/ 24840039, Fax: (965) 24845652. Fawaz Al Zayani Establishment, P.O. Box 42426, Shop No. 18, Al Humaizi Commercial Complex, Khalifa Al Jassim, Shuwaikh, Kuwait. Tel: (965) 24828710, Fax: (965) 24828716. Fawaz Al Zayani Establishment, P.O. Box 42426, Shop No.18, Al Humaizi Commercial Complex, Khalifa Al Jassim, Shuwaikh, Kuwait. Tel: (965) 24828710, Fax: (965) 24828716. Fawaz Al Zayani Establishment, Fahaheel Industrial Area, Main St., Sanaya, Kuwait. Tel: (965) 23925830, Fax: (965) 24828716. **LEBANON:** Est. Shaya & Azar S.A.R.L., Boulevard Jdeideh - Mar Takla - Bouchrieh. P.O. Box 90545 Jdeideh.Beirut - Lebanon. Tel: 00961 1 872305 / 306 , Fax: 00961 1 872303. **LIBYA:** North Africa Trading ( El Ghoul Brothers), AlHilal Service Center Tawergha St. Misurata. Tel: 00218-091-3221408. **(Benghazi)** Sniydal st., Amr Ibn El-Aas Rd. Tel: (+218) 92 5771120. **(Tripoli)** Al Barniq Service Center, Mokhazin elskar st., ElFallah. Tel: (+218) 21 4808019. **(Misrata)** Al Hilal Service Center, Tawergha st. Tel: (+218) 51 2626743. **MAURITIUS:** Robert Le Marie Limited, Old Moka Road, Bell Village, P.O. Box 161, Port Louis, Tel: 00230-212 1865/ 212 2847, Fax: 00230-2080843. **MOROCCO:** Ets Louis Guillaud & Cie, 149, Quartier Industriel, Moulay Rachid, Casablanca, Postal Code 20450, Morocco. Tel: 00212-522729233, Fax: 00212-522729096. **NIGERIA:** Meridian Power Tools Ltd., Gr.Floor, #1 Alhaji Masha Rd, Next to Teslim Balogun Stadium, Near National Stadium Surulere, Lagos, Nigeria. Tel: 00234-1-7740431 / 7740410, Fax: 00234-1-7913798. **OMAN:** Al Jizzi Company LLC, P.O. Box 1704, PC 112 Ruwi, Oman. Tel: (968) 24832618/ 24835153, Fax: (968) 24831334/24836460. Al Hassan Technical & Construction Supplies Co. LLC, P.O. Box 1948, P.C. 112, Ruwi, Tel: (968) 24810575 / 24837054, Fax: (968) 24810287/ 24833080. Oman Hardware Co. LLC, P.O. Box 635, Ruwi Postal Code 112, Tel: (968) 24815131, Fax: (968) 24816491. Khimji Ramdas, P.O. Box 19, Post Code 100, Ghala, Muscat, Oman. Tel: (968) 24595906/ 907, Fax: (968) 24852752. Oman Marketing & Service Co. (Omasco), P.O. Box 2734, Behind Honda Showroom, Wattayah, Oman. Tel: (968) 24560232/ 24560255, Fax: (968) 24560993. Oman Marketing & Service Co. (Omasco), Al Ohi, Sohar, Oman. Tel: (968) 26846379, Fax: (968) 26846379. Oman Marketing & Service Co. (Omasco), Sanaya, Salalah, Oman. Tel: (968) 23212290, Fax: (968) 23210936. **PAKISTAN:** ZIT Co - Nasir & Bros., 2nd Floor, Qadri Center, Chokwal Dargan Railway Road, Lahore, Pakistan. Tel: 0092 42 37670839, Fax: 0092 42 37652989. Ammar Service & Spares, 60-Bank Arcade, Serai Road, Karachi, Pakistan. Tel: (92-21) 32426905, Fax: (92-21) 32427214. **QATAR:** Teyseer Industrial Supplies & Services Co. W.L.L, 55, Al Wakalat St. (Between St. 18 & 19) Salwa Industrial Area, P.O. Box 40523 Doha, Qatar. Tel: (974) 44581536, Fax: (974) 44682024. Shaheen Electrical Works & Trading Co. W.L.L, Gate 34, St. 44 Industrial Area P.O. Box 9756, Doha, Qatar. Tel: (974) 44600230 / 44600525, Fax: (974) 44601338. Al Mufah Service Centre, Al Wakrah Road, P.O. Box 875, Doha, Qatar. Tel: (974) 44650880/ 44650110/ 44446868, Fax: (974) 44441415 / 44662599. **SAUDI ARABIA: (Al Bahr)** Mohamed Ahmed Bin Afif Est., P.O. Box 530, Yanbu, Al Bahr. Tel: (966-4) 3222626/ 3228867, Fax: (966-4) 3222210. **(Al Khobar)** Fawaz Ibrahim Al Zayani Trading Est., P.O. Box 76026, Al Khobar # 31952, Tel: (966-3) 8140914, Fax: (966-3) 8140824. MSS (Al-Mojil Supply & Services) P.O. Box 450, Jubail 31951, Opp. Gulf Bridge Library & Riyadh House. Tel: (966-3) 3612850/ 3624487/ 3621729, Fax: (966-3) 3623589/ 3620783. **(Dammam)** MSS (Al-Mojil Supply & Services), P.O. Box 450, Jubail 31951, Opp-Gulf Bridge Library & Riyadh House. Tel: (966-3) 3612850 / 3624487 / 3621729, Fax: (966-3) 3623589 / 3620783. **(Al Bawardi Tools & Hardware)**, P.O. Box 112, Dammam, Tel: (966-3) 8330780 Ext.24 / 8348585 Ext. 24 / +966-3-8335555, Fax: (966-3) 8336303. **(Al Hassa)** Mutawa Trading & Gen. Services, Maliki road Hafuf city, Al Hassa, KSA. Tel: (966) 502466275 **(Jeddah)** Al Bawardi Tools & Hardware, P.O. Box 16905, Jeddah 21474, Tel: (966-2) 6444547 / 6439035 / 6456095, Fax: (966-2) 6439024. EAC (Al Yousef Contg. & Trdg. Est.), P.O. Box 30377, Jeddah -21477, Tel: (966-2) 6519912, Fax: (966-2) 6511153. **(Madina)** Garziz Trading for Bldg Mat & Decoration, P.O. Box 3364, Madina. Tel: (966-4) 826 14 90 / 8227636, Fax: (966-4) 8265741. **(Riyadh)** Industrial Material Organization (IMO), P.O. Box 623, Rial Street, Riyadh, Tel: (966-1) 4028010 Ext 26 / 8001245757, Fax: (966-1) 4037970. Sultan Garment Factory (RSC), P.O. Box 29912, Riyadh 11467, KSA, Tel: (966-1) 4055148 / 4042889, Fax: (966-1) 4055148. Al Bawardi Tools & Hardware, P.O. Box 68, Riyadh 11411, Tel: (966-1) 4484999, Fax: (966-1) 4487877. **(Yanbu)** Fawaz Ibrahim Al Zayani, Opposite to Al Fouzan, Jeddah highway or King Abdul Aziz road, Yanbu. Tel: (966-4) 3960980, Fax: (966-4) 3961980. Mohamed Ahmed Bin Afif Est., P.O. Box 530, Yanbu, Al Bahr, Tel: (966-4) 3222626/ 3228867, Fax: (966-4) 3222210. **SOUTH AFRICA:** Stanley Black & Decker - RSA, 199 Winetree Drive Stormill Exit 9 Rooodepoort. Tel: (2711) 472 0454, Fax: (2711) 472 0482. Trevco Power Tool Service 14 Steenbok Street, Koedoespoort, 0186, Pretoria, South Africa. Tel: (27-86) 1873826, Fax: (27-86) 5001771. **TANZANIA:** General Motors investment Ltd., P.O. Box 16541, 14 Nyerere Road, Vingunguti, Dar-es-Salaam. Tel: (255 22) 2862661/ 2865022, Fax: (255 22) 2862667. **TUNISIA:** Societe Tunisienne De Maintenance (STM), Rue de la Physique. Nouvelle Zone Industrielle Ben Arous., 2013 Ben Arous, Tunisia. Tel: (+216) 79 389687, Fax: (+216) 71 385154. **UAE: (Abu Dhabi)** Light House Electrical, P.O. Box 120, Abu Dhabi. Tel: (971-2) 6726131, Fax: (971-2) 6720667. Galaxy Equipment Trading, Madinat Zayed (Baada Zaid), Abu Dhabi P.C. 58910, Tel: (971-2) 8844279, Fax: (971-2) 8844297 **(Ajman)** Al Sukoon Gen. Trdg. Co. LLC, P.O. Box 2975, Ajman. Tel: (971-6) 7435725/ 7438317, Fax: (971-6) 7437350, Al Sukoon Gen. Trdg. Co. LLC, P.O. Box 2975, Ajman, Tel: (971-6) 7435725 / 7438317, Fax: (971-6) 7437350 **(Al Ain)** Zillion Equipment and Spare Parts Trading LLC, P.O. Box 19740, Opp. Bin Sada/ Trimix Redymyic Sanaiya, Al Ain. Tel: (971-3) 7216690, Fax: (971-3) 7216103. **(Dubai)** Black & Decker (Overseas) GmbH, P.O. Box 5420, Dubai. Tel: (971-4) 8127400/ 8127406, Fax: (971-4)2822765. Ideal Star Workshop Eqpt.Trading LLC, P.O. Box 37116, Al Quoz, Dubai. Tel: (971-4) 3474160, Fax: (971-4) 3474157, Fine Tools, P.O.Box 30139, Al Quoz, Dubai, Tel: (971-4) 3385240, Fax: (971-4) 3385239, Albreah Engineering Service, P.O. Box 78954, Al Qusais , Dubai. Tel: (971-4) 2850044, Fax: (971-4) 2848402. **(Musafah)** Light House Electrical, P.O. Box 120, Abu Dhabi. Tel: (971-2) 5548315, Fax: (971-2) 5540461. **(Sharjah)** Mc Coy Middle East LLC, P.O. Box 25793, Sharjah, Tel: (971-6) 5395931, Fax: (971-6) 5395932. Burj Al Madeena, Industrial Area No.1, Opp. Pakistani Masjid, P.O. Box 37635, Sharjah. Tel: (971-6) 5337747, Fax: (971-6) 5337719. Burj Al Madeena , Industrial Area No 1, opp Pakistani Masjid P.O. Box 37635, Sharjah, Tel: (971-6) 5337747, Fax: (971-6) 5337719 **(Ras Al Khaimah)** Mc Coy Middle East LLC, P.O. Box 10584, Ras Al Khaimah, Tel: (971-7) 2277095, Fax: (971-7) 2277096. **UGANDA:** The Building Center (U) Ltd., 52 Station Road, Kitgum House, P.O. Box 7436, Kampala, Uganda. Tel: (256-41) 4234567/ 4259754, Fax: (256-41) 4236413. **YEMEN: (Aden)** Middle East Trad. Co. Ltd. (METCO), Mualla Dakka, Aden, Yemen. Tel: (967-2) 222670, Fax: (967-2) 222670. **(Sana'a)** Middle East Trad. Co. Ltd. (METCO), Hayel St., Sana'a, Yemen. Tel: (967-1) 204201, Fax: (967-1) 204204. **(Taiz)** Middle East Trading Co. (METCO), P.O. Box 12363, 5th Flr, Hayel Saeed Anam Bldg, Al-Mugamma St. Taiz, Yemen. Tel: (967-4) 213455, Fax: (967-4) 219869.